



PRODUCT BROCHURE

Double Image Microscope

Our range of digital microscopes, with single or twin cameras, meets the different needs for substrate visualisation and fine alignment.

Idonus proposes a range of modular digital microscopes suitable for the observation of micromechanical parts and micrometre-scale features. The basic system is a Single Image Microscope (*SIM*) with reflected light illumination. When used in pairs and mounted on an adjustable stand, it provides a Dual Image Microscope (*DIM*) designed for on-screen visualisation during in-plane alignment operations (e.g., when combined with our shadow mask aligner, *SMA*).

Applications

The primary use of our cost-effective digital microscopes is for UV photolithography in cleanrooms. Before UV exposure, the substrate needs to be precisely aligned with a mask and this procedure can be completed using one of our digital microscope. Our products are thus designed to allow bulky auxiliary equipment to be placed under the units. For example, many of our clients use the Dual Image Microscope (*DIM*) as a laboratory equipment for on-screen visualisation during fine in-plane alignment operations. A typical application is illustrated in [Figure 1](#) where a *DIM* is combined with our Shadow Mask Aligner (*SMA*).

Working principle

Our series of digital microscopes integrate reflected light optics, also referred to as episcopic illumination (or epi-illumination). This illumination means is applicable for the observation of a wide range of materials and meets most needs in terms of inspection of microsystems.

Köhler illumination – Quality of the illumination is an essential criterion in optical microscopy. This is especially true for quantitative digital imaging. We integrate a light emitting diode (LED) system that provides homogenous illumination thanks to the Köhler illumination technique.¹ With this lighting optics, the light source is completely defocused and not visible in the resulting image (see [Figure 2](#)). This ensures high-quality imaging and usability of the recorded images for post-processing (e.g., for machine vision).

Green LED – Green light illumination comes as

standard, as it is a wavelength (around 550 nm) suitable for UV applications. Any other wavelength is of course possible. In particular, IR illumination and IR sensitive cameras are available upon request. Note that Idonus also proposes an IR microscope dedicated to the inspection of buried silicon oxide (SiO₂) in silicon-based wafers.²

Range of products

Our Single and Dual Image Microscopes (*SIM / DIM*) are all built from a tubular optical module whose principle is depicted in [Figure 1](#). The constitutive elements of our *SIM* series of digital microscopes are:

- *SIM* optics
 - ×1 Tubular optics with integrated homogeneous green light LED illumination
 - ×1 Fixed-magnification objective (focusing is ensured with a knob for the “infinity corrected”

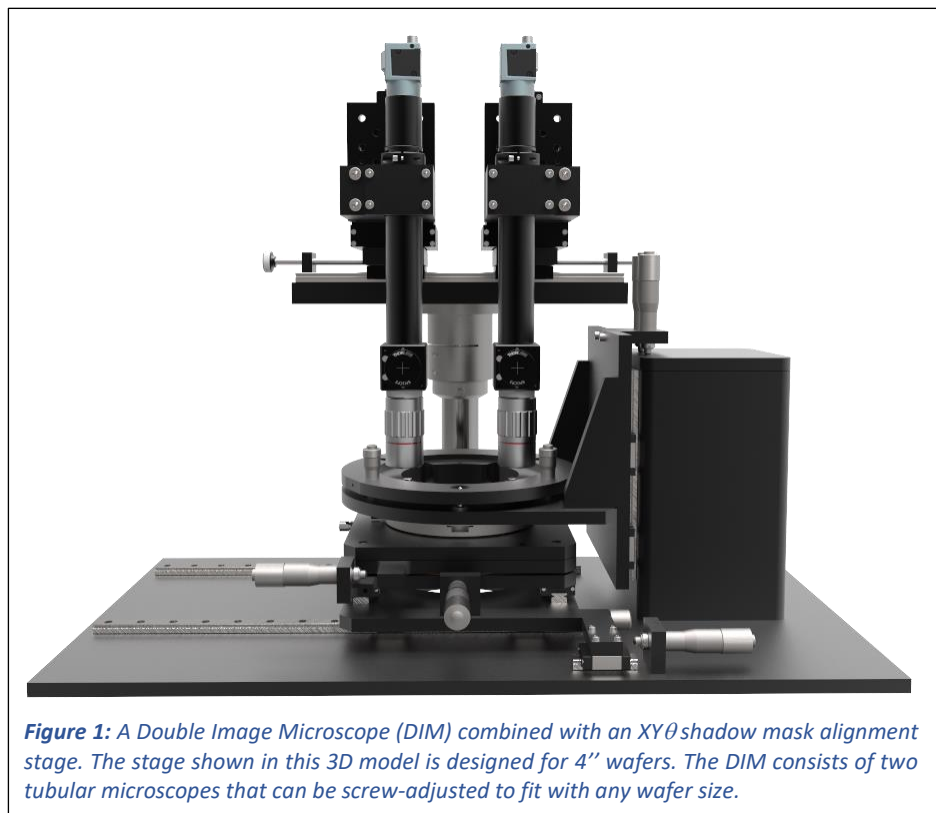

Figure 1: A Double Image Microscope (*DIM*) combined with an *XYθ* shadow mask alignment stage. The stage shown in this 3D model is designed for 4" wafers. The *DIM* consists of two tubular microscopes that can be screw-adjusted to fit with any wafer size.

¹ A. Koehler, "New method of illumination for photomicrographical purposes," *Journal of the Royal Microscopical Society*, vol. 14, pp. 261-262, 1894.

² For further details on our IR-microscope, check our website: idonus.com/products/mems-products/infrared-microscope.html

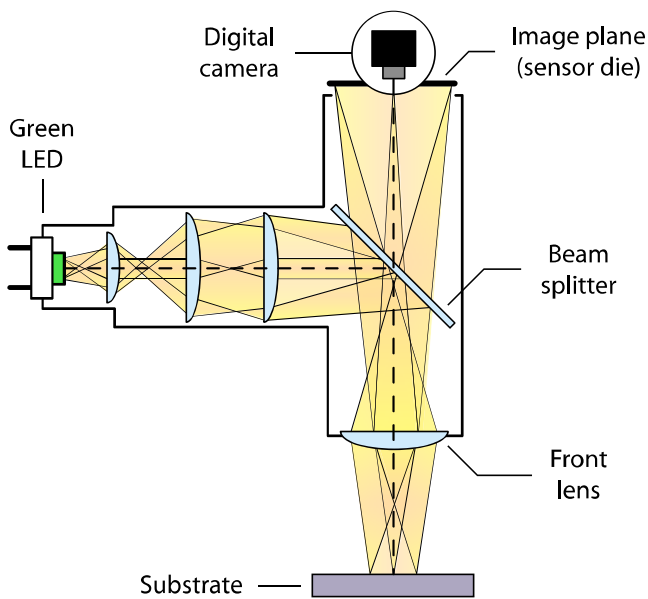

Figure 2: Working principle of Köhler illumination in epillumination. The lighting is defocused and provides homogeneous sample illumination.

versions / no focusing is needed for telecentric optics)

- ×1 digital camera with USB connection
- Power supply and control unit for the LED light
- Main body with a flat mounting base
 - Fine screw-adjustable height positioning (Z direction)
 - Fine screw-adjustment for the X and Y positions
- Software for real-time on-screen visualisation of the digital images³

The same elements are found in our *DIM* series, but in that case with two tubular microscopes instead of only one. In the *DIM* microscopes, two cameras are connected to a PC and provide twin images for the inspection of two distinct zones on the substrate.

A few examples of possible configurations are shown in [Figure 3](#). To meet our client's needs, many other configurations are possible with our modular system. For example, as an alternative to our *DIM* system, one can use a *SIM* microscope mounted on a slide rail with stoppers.

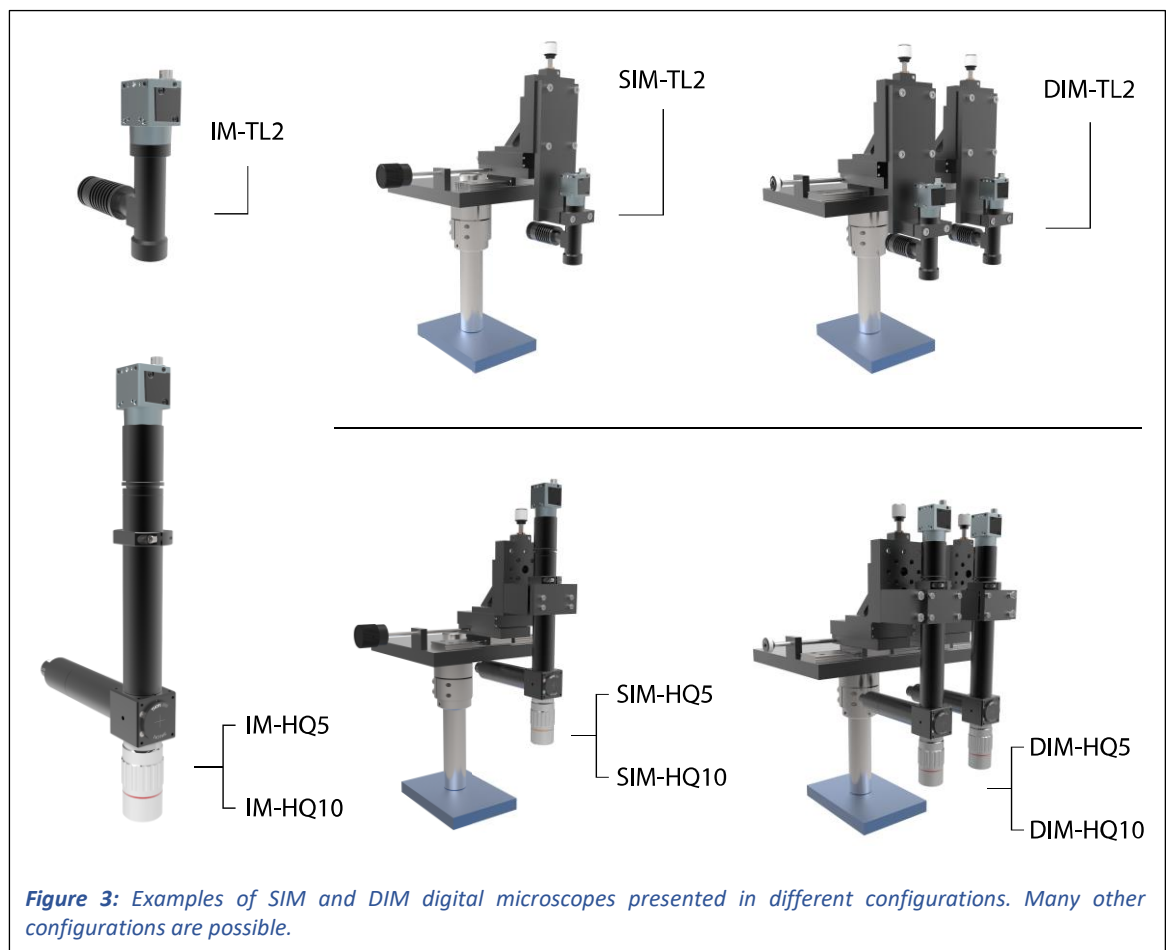

Figure 3: Examples of SIM and DIM digital microscopes presented in different configurations. Many other configurations are possible.

³ The digital camera must be connected to a PC running Windows OS. PC and screen are not provided.

Table 1: Products specifications.

Camera	C-mount CMOS sensor, monochrome, 25 fps 2 MP resolution (1920 px × 1080 px), 12 bits pixel depth 2.2 μm × 2.2 μm pixel size (sensor size: 4.2 mm × 2.4 mm)		
Coaxial illumination	Green LED (standard), adjustable intensity (with the control unit) <i>Any other wavelength available on request</i>		
Optics		Telecentric tube	Infinity corrected tube
	Model	IM-TL2	IM-HQ5 IM-HQ10
	Magnification	×2	×5 ×10
	FoV Field of View	2.1 × 1.2 mm	0.8 × 0.5 mm 0.4 × 0.25 mm
	WD Working Distance	65 mm	35.1 mm 36.9 mm
Resolution*	4.6 μm	2.23 μm 1.34 μm	
Mechanics			
Z travel range	1.00" (25.4 mm), fine adjustment screw		
Y travel range	1.00" (25.4 mm), fine adjustment screw (front – back displacement, relative to the operator)		
	SIM model	SIM-TL2	SIM-HQ5 SIM-HQ10
X travel range	left – right, relative to the operator	135 mm (± 67.5 mm)	
	DIM model	DIM-TL2	DIM-HQ5 DIM-HQ10
X travel range	left – right, relative to the operator	Min. 50 mm – Up to 200 mm	
Dimensions			
Tube dimensions	H ₁ × D ₁ (mm × mm)	130 × ø26	355 × ø34
External dimensions SIM	H × W ₁ × W ₂ (mm × mm × mm)	500 × 370 × 330	533 × 370 × 330
External dimensions DIM		490 × 515 × 330	490 × 515 × 330

*) Resolution of the complete system (digital camera + optics).

Specifications

Our product range spans three fixed magnifications: ×2, ×5 and ×10 magnifications are available as standard. The specifications of our different products are summarized in Table 1. For quotation request, please indicate the product reference as follows:

-	IM-	TL2
S		HQ5
D		HQ10

As highlighted in the example, reference **DIM-HQ10** is for the Double Image Microscope (*DIM*) with a ×10 magnification optics (infinity corrected tube). If you wish to use our telecentric tubular microscope with a custom-made stage, the reference IM-TL2 is for the telecentric tube alone.

Creative engineering and manufacturing • Our engineering team is accustomed to developing products according to client's needs. In-house machining and assembling facilities shorten the time from concept to finished products.

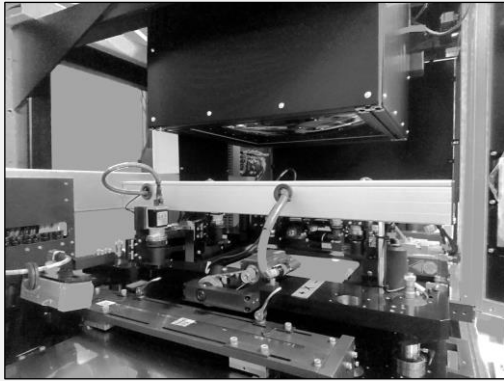

Customized UV-LED exposure system installed on a roll-to-roll machine

Visit our website to have an insight into our other products and activities. Contact us for further technical information and to obtain a quotation.

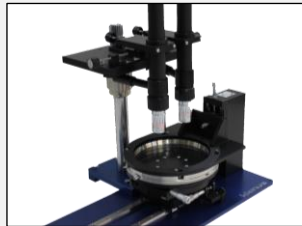

Double image microscope

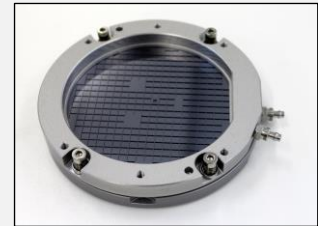

A model of wafer chuck

About Idonus

Founded in 2004, Idonus is a Swiss company that develops and manufactures special equipment for the MEMS and watchmaking industries. Our product portfolio includes UV-LED exposure systems for photolithography, IR microscope for wafer inspection, vapor phase chemical etcher for silicon-based devices. Since 2016, we also provide ion implantation services and machines for the surface treatment of materials.

Contact us for
more details:

Sales idonus
sales@idonus.com

idonus
creative engineering and manufacturing

Idonus sàrl
Rouges-Terres 61
CH – 2068 Hauterive

T: +41 32 724 44 40
info@idonus.com
idonus.com